

# *PROFESSIONAL* SERIES

Advanced, High Productivity CO<sub>2</sub> Laser Systems for Engraving, Cutting and Marking

**UNIVERSAL**  
LASER SYSTEMS INC.



PROFESSIONAL  
SERIES

UNIVERSAL  
LASER SYSTEMS INC.

### **Introduction**

Universal Laser Systems has been building and designing computer-controlled CO<sub>2</sub> laser cutting and engraving systems since 1988 and manufacturing CO<sub>2</sub> lasers since 1997. We have built more laser cutting and engraving systems than any other manufacturer in the industry. No other company has more experience building CO<sub>2</sub> laser equipment than Universal!

### **Value**

A good measure of a product's value is what it is worth after the initial purchase. Universal Laser Systems has the highest resale value of any laser system when comparing field size and laser power levels. At Universal, we build CO<sub>2</sub> lasers and laser systems for the long haul and continue to support every machine we've made.

### **Get the Universal Advantage**

At Universal Laser Systems, Inc., taking care of our customers after the sale is our top priority. You can feel confident that we will stand behind our products and be there for you when you need us. We want to help you succeed in the market application you plan to pursue with your Universal Laser System. Whether you are a start-up company or an established business, we have the tools and experience

necessary to help you maintain a competitive advantage. Our applications lab can assist you with materials testing and our sales engineers will be happy to assess your needs and recommend the appropriate configuration from our extensive selection of laser platforms, laser cartridges and accessories.

Universal Laser Systems is a team of experienced, enthusiastic people who are focused on your success now and in the future. Call us at 800-859-7033 for more information or to arrange a demonstration.

### **About Universal Laser Systems, Inc.**

Universal Laser Systems, Inc. is an industry pioneer and highest volume manufacturer of computer-controlled CO<sub>2</sub> laser systems used for laser marking, engraving and cutting operations. We have designed, manufactured and shipped thousands of CO<sub>2</sub> laser systems worldwide. Universal is also one of the world's largest suppliers of CO<sub>2</sub> lasers. In 1998 we introduced the industry's first complete line of air-cooled, RF-excited CO<sub>2</sub> lasers. Since then, we have consistently outpaced the market with new state-of-the-art technological advancements in CO<sub>2</sub> lasers and laser systems.

# Professional Laser System

ULS V-groove rail system with self-adjusting bearings that never need lubrication.

Top door for easy access to the work table.

Heavy duty worktable supported on three leadscrews. Motorized Z-axis can be manually adjusted or can be automatically moved to multiple focus positions from a single job file.

Tri-layer laminated safety glass window is heat-and scratch-resistant and provides excellent visibility of the work area.

LCD display shows current file name, laser power, engraving speed, run time, setup and diagnostic menus.

Red dot pointer can be used with manual jogging to find a location and to check work piece alignment. Motion system can be moved to check location from the system keypad or from computer cursor keys.

Front loading door for inserting materials and work trays.

Integrated cart with storage space.



Universal's Professional Series of CO<sub>2</sub> laser systems provide an unbeatable combination of high power (up to 120 watts using dual lasers), three platform sizes and an advanced, materials-based print driver that delivers consistently excellent cutting and engraving results. The Professional Series systems are ideal for high-speed cutting jobs; deep, high-throughput engraving; and fast, permanent marking.

Three platform sizes to fit your exact budget and applications: 24"x12"; 24"x18"; 32"x18".



### User Control Panel

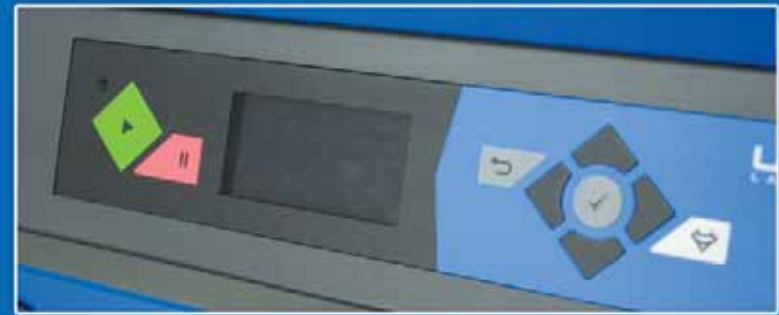

### Lens Carriage



### Rapid Reconfiguration

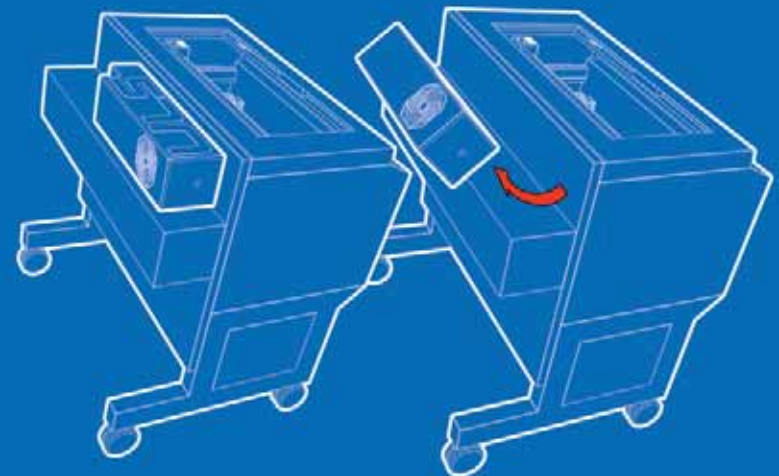

### Exclusive Laser Engine, Software and System Synergy

The entire Professional Series laser system – including the CO<sub>2</sub> laser cartridge, platform chassis, electronics and software interface – is designed and manufactured by Universal Laser Systems. Every aspect of the system has been tuned to work together in perfect harmony to provide the best possible cutting, marking and engraving quality. Universal's superior engineering and innovative technology result in systems that provide years of profitable, reliable and productive service.

## Additional Features

- The Professional series is designed for new and experienced users with demanding production requirements.
- The advanced Laser Interface<sup>+</sup> materials-based print allows user to choose between automatic and manual settings.
- Systems are available with 10 to 120 watts of air-cooled laser power.
- Field upgradeable firmware and software and flash upgradeable electronics extend the useful life of the system.
- Four focusing modes are available, including motorized manual focus, auto focus, focusing from front LCD panel and through the print driver.
- A 2.0" (50mm) focal length lens is standard; optional lenses are available.
- Users can set and run multiple focus settings in same job.
- Users can save, store and load material job settings on the fly.
- Run time estimator provides an estimate of the time needed to run a job.
- Relocatable origin resets the home position origin to work with your graphic software.
- Proportional pulse control (patented) provides user-definable spacing between laser pulses for better engraving or cutting quality.
- Multiple language support is available for ease of operation.
- The system auto-detects the rotary fixture, cutting table and air compressor upon installation.
- Shielded, interchangeable focusing optics stay cleaner for a longer period of time.

**PLS3.60**

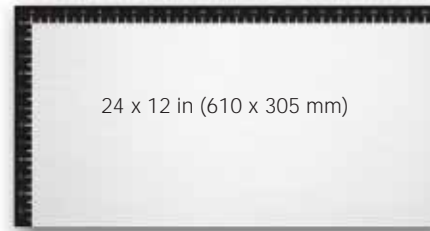

**PLS4.60**

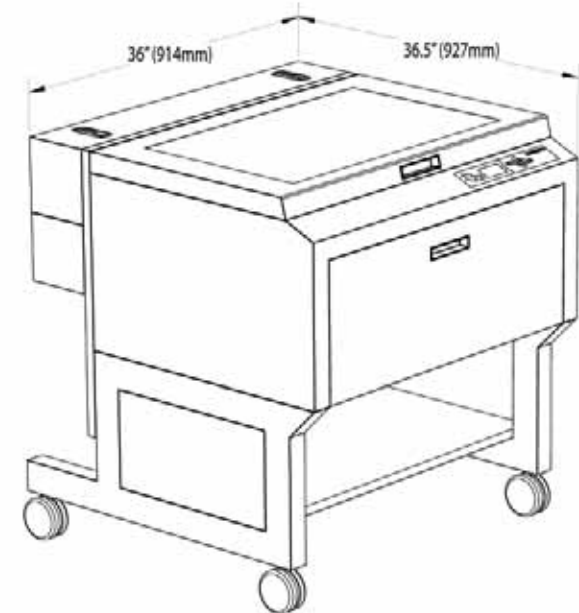
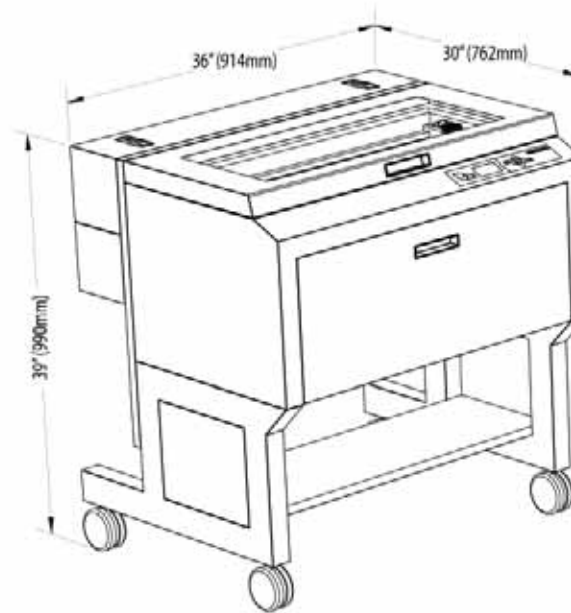

## PLS6.60

32 x 18 in (813 x 457 mm)

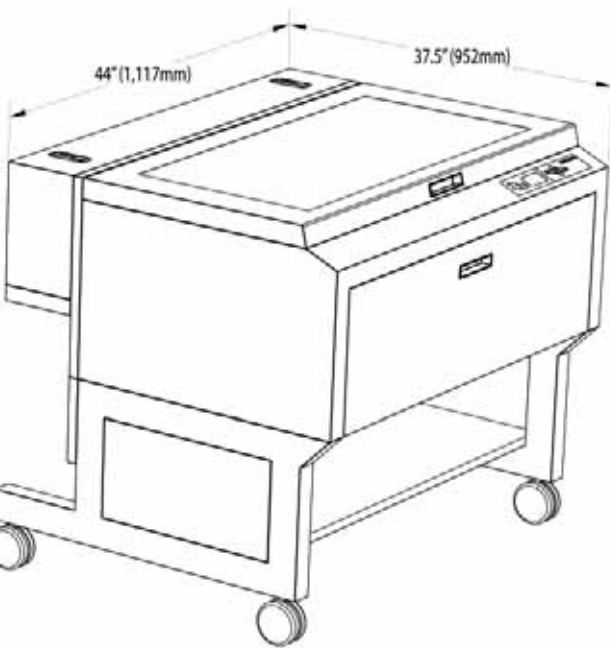

# Universal's Engineering

## Superior Engineering Saves You Time and Money

Thanks to innovative technology and superior engineering, Universal's laser systems provide the lowest cost of ownership in the industry. Motors and belts can be replaced easily and inexpensively by the user with simple hand tools. Universal's laser recharge costs are by far the lowest in the industry, and lasers are promptly remanufactured to "like new" condition. Universal is dedicated to keeping your system up and running at the least possible expense and inconvenience to you.

## Motion System Bearings

Universal's Professional Series features permanently sealed, self-adjusting and self-lubricating precision motion system bearings that allow for excellent engraving quality. The motion system bearings typically provide years of trouble-free service life and can be easily replaced by the user at a very low cost. Our own reliability testing has shown that this design provides the best combination of engraving and cutting quality, price and durability compared to any other bearing.

## Maintenance Free Drive Motors

Provide excellent reliability and torque for outstanding accuracy; allows precise X-Y positioning at any point on the work table for extremely accurate cutting and engraving; provide for easy and inexpensive replacement should servicing become necessary.

## Kevlar Reinforced Drive Belts

Durable stretch-free belts provide accurate positioning at high speeds and ensure long life without the need for lubrication, maintenance or adjustments.

## Enclosed (Shielded) Optics with Quick Release Covers

Enclosed focusing lens and mirror assembly ensures that optics remain cleaner for a longer time and simplifies periodic inspection, cleaning and maintenance.

## Lightweight Moving Parts

Low-inertia motion carriage design allows for incredibly quick raster engraving start/stop times and amazingly agile vector cutting. Also helps increase parts life while reducing maintenance.

## Highly Modular Parts

Provides users with quick and easy access to parts for upgrades or replacement in the field in just minutes using common hand tools; almost all procedures can be performed without factory servicing or a field technician.

## Synergistic Design

Universal Laser Systems is the only manufacturer that designs and builds CO<sub>2</sub> lasers as well as the computer-controlled laser systems they are used in. Every aspect of a Universal laser system is designed to work together as a well-tuned package. The end result is laser cutting, marking and engraving systems with accurate, efficient and reliable performance.

# Laser Interface +™

Automatic



Manual

Universal's Professional Series features the world's most advanced, powerful and flexible print driver: the Laser Interface+. Laser Interface+ is a materials-based print driver that automatically calculates the power and speed settings for a wide range of laser-friendly materials to ensure consistently good results for experienced and novice users alike.

The next-generation Laser Interface+ print driver used in the Professional Series gives users their choice between automatic or manual control over power, speed, pulses per inch and many other system settings. Users can toggle between automatic and manual modes for "live" control over speed and power setting while a job is running, then adjust and save the parameters in a custom database by

material type, job number, person running the machine or any other user-defined category. Users can store and run up to 2000 jobs and change or restore job parameters on the fly.

Laser Interface+ features an intuitive and highly functional graphical user interface (GUI) that provides information about system status, installed accessories, laser power, pop-up operating tips and warnings.

Just a few additional benefits of the Laser Interface+ include precise control over features such as proportional power control, PPI (pulses per inch), fully adjustable 3D contouring and rubber stamp shouldering. There are color-linked settings for



The Laser Interface+ materials-based print driver includes a print preview function which allows users to preview a job on-screen before it is actually run to ensure proper setup. Users can also view and re-run jobs directly from the system at a later time without the need to open the graphic software file.

combined raster/vector, raster only, vector only or skip modes which allow the user to fine tune engraving and cutting parameters. Laser Interface+ also includes built-in vector graphic scaling to compensate for material melt-back and beam diameter on high-accuracy cutting jobs and the ability to incorporate multiple power and speed settings within the same job to increase throughput and versatility. There are even automatic image enhancements that optimize the way that the laser beam fires in order to produce superior quality images at the highest speeds possible.

No other laser system manufacturer offers the power, flexibility and convenience of the Laser Interface+ materials-based print driver.

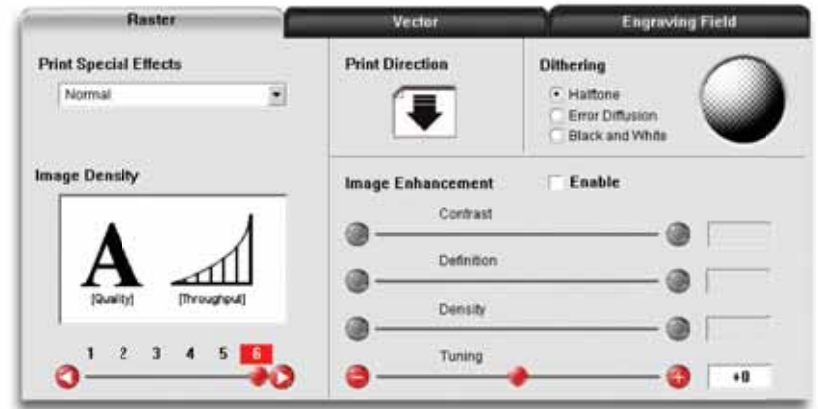

Laser Interface+ includes resolution enhancement technology that improves image quality even at low print resolutions to increase quality and productivity. Tuning and high speed image enhancements allow for fine tuning of images, including laser and material interaction through the driver, to produce better quality engraving on critical jobs.

### Software Compatibility

Unlike most laser manufacturers who force their customers to use proprietary programs, Universal's Professional Series laser systems are fully compatible with most popular Windows® graphic software including CorelDRAW®, AutoCAD®, Adobe Photoshop®, Microsoft® Word, and most bar coding and labeling software.

The Professional Series features a full-function Windows® XP/Vista print driver specifically designed to optimize your Windows® graphic software for laser cutting, marking and engraving operations.

## Universal's Quick Change CO<sub>2</sub> Lasers

Once you have chosen a Professional Series platform, choose the laser power required for your specific application. Our patented Quick Change Lasers™, which utilize patented Rapid Reconfiguration™ technology, allow you to reconfigure your Universal laser system(s) to different power levels in seconds without the need for tools or optical alignment to accommodate changing production requirements.

Universal laser cartridges come in 10, 25, 30, 35, 40, 45, 50, 55 and 60-watt configurations.

The benefits of Quick Change Lasers are obvious: If you own a 25-watt PLS3.60 you can exchange it for a high power laser as your business expands. Or you can exchange a 60-watt laser from your PLS4.60 and add it to the existing 60 watts of your PLS6.120D, giving you a total of 120 watts of power – perfect for large shops requiring fast production rates!

Universal manufactures the highest quality CO<sub>2</sub> lasers:

- Wide Selection of Power Levels
- Air-Cooled 10-120 Watts
- Patented Permalign™ - No Optical Beam Alignment Installation
- Patented Cross-Platform Compatibility
- Patented Laser Design
- High Reliability, Excellent Power Stability
- Available warranty up to 5 years



## Universal Offers the Lowest Recharge Cost in the Industry

Universal Laser Systems is the only manufacturer that manufactures both CO<sub>2</sub> lasers and CO<sub>2</sub> laser cutting and engraving systems. Our quick-change laser design makes changing out the cartridge a simple no-tools operation. We are the only manufacturer to supply our customers with completely remanufactured laser cartridges when the original cartridge reaches the end of its service life. We don't simply recharge your laser cartridge – we completely remanufacture it to like-new specifications, including the optics and electronics. When you purchase a Universal laser, you can save literally thousands of dollars with one of the most reasonable and affordable laser recharging and remanufacturing services in the industry.



## How Much Laser Power Do You Need?

The amount of laser power you choose should meet the majority of your production requirements. For example, a 10-watt laser is capable of cutting and engraving 1/8" wood, but only at very slow speeds. More wattage can greatly increase your productivity. Also, some operations, such as metal marking, require a minimum of 30 watts of laser power. Our sales engineers can advise you on the amount of power that will best meet your current and future application needs.

### **10 Watts**

Entry level power for light surface engraving operations and cutting thin materials.

### **20-30 Watts**

Low-medium power level for moderate speed cutting and engraving and high speed low power engraving. Not recommended for thick cutting operations or dual head applications.

### **40-60 Watts**

Medium power level for deeper, high speed engraving and thick cutting operations at average speeds.

### **60-80 Watts**

Medium-high power level that is ideal for high productivity engraving and cutting operations.

### **80-120 Watts**

High power for heavy cutting and deep, high throughput engraving. Ideal for use with dual head. In a dual laser system (PLS6.120D), turning one laser off is helpful for precision engraving of very low power materials.

## Product Line



### **PLS3.60 - 24"x12"**

The PLS3.60 is an advanced laser platform that offers industry standard table size and compatibility with up to 60 watts of laser power. Ideal for both new and experienced users with high productivity needs, the PLS3.60 is compatible with all ULS accessories including the rotary fixture for glassware and the downdraft honeycomb cutting table for improved cutting. Auto Focus and Red Dot Pointer standard.

### **PLS4.60 - 24"x18"**

The Universal PLS4.60 delivers an impressive combination of size and performance. This popular laser platform features an 24"x18" work table – a full 50 percent more work area than the industry standard 24"x12" table size. Capable of high speed/high throughput cutting and engraving operations, the PLS4.60 is compatible with lasers up to 60 watts and all popular accessories including the production enhancing Dual Head that allows laser processing of two identical jobs at the same time. Auto Focus and Red Dot Pointer standard.

### **PLS6.60 - 32"x18"**

The PLS6.60 is the seasoned professional's step up into high production laser processing. This overachieving laser platform features an impressive 32"x18" work table and is compatible with lasers up to 60 watts and all popular accessories. Capable of deep, high speed engraving and thick cutting operations, the PLS6.60 is compatible with the production enhancing Dual Head. Auto Focus and Red Dot Pointer standard.

### **PLS6.120D - 32"x18"**

The PLS6.120D is an exciting combination of large 32"x18" work table, compatibility with all popular accessories and dual laser capability for up to 120 watts of power using two laser cartridges. Using two laser cartridges has advantages over a single higher power laser, including better low power stability and more security knowing that your laser system will still be productive with one laser. It is common to own a PLS6.120D and use it with two lasers for high power cutting jobs and then take one laser out and use it in another laser platform, allowing two different jobs to be performed at the same time. As an economical way to step into the PLS6.120D, consider purchasing it with one laser. When production demands require it, you can simply purchase and install a second laser.

# Specifications

	<b>PLS3.60</b>	<b>PLS4.60</b>	<b>PLS6.60</b>	<b>PLS6.120D</b>
Work Area	24" x 12" (610mm x 305mm)	24" x 18" (610mm x 457mm)	32" x 18" (813mm x 457mm)	32" x 18" (813mm x 457mm)
Table Size	29" x 17" (737mm x 432mm)	29" x 23" (737mm x 584mm)	37" x 23" (940mm x 584mm)	37" x 23" (940mm x 584mm)
Maximum Part Size	29"W x 17"H x 9"D 737mm x 432mm x 229mm	29"W x 23"H x 9"D 737mm x 584mm x 229mm	37"W x 23"H x 9"D 940mm x 584mm x 229 mm	37"W x 23"H x 9"D 940mm x 584mm x 229 mm
Overall Dimensions	36"W x 38"H x 30"D 914mm x 965mm x 762mm	36"W x 39"H x 36.5"D 914mm x 991mm x 927mm	44"W x 39"H x 37.5"D 1118mm x 991mm x 953 mm	44"W x 39"H x 37.5"D 1118mm x 991mm x 953 mm
Laser Power Options	10, 25, 30, 35, 40, 45, 50, 55, 60 watts	10, 25, 30, 35, 40, 45, 50, 55, 60 watts	10, 25, 30, 35, 40, 45, 50, 55, 60 watts	10, 25, 30, 35, 40, 45, 50, 55, 60 Select any two lasers for up to 120 watts combined power
Weight	235 lbs. (107 kg)	270 lbs. (123 kg)	325 lbs. (148 kg)	345 lbs. (156 kg)
User Interface	Keypad and LCD	Keypad and LCD	Keypad and LCD	Keypad and LCD
Printer Control / Connection	Windows XP/ Vista; USB 2.0*	Windows XP/ Vista; USB 2.0*	Windows XP/Vista; USB 2.0*	Windows XP/Vista; USB 2.0*
Power Requirements	110V/10A or 220V/5A; 50/60Hz	110V/10A or 220V/5A; 50/60Hz	110V/10A or 220V/5A; 50/60Hz	220V/15A; 50/60Hz
Exhaust Connection	External exhaust required: Port is 4 inches in diameter	External exhaust required: Port is 4 inches in diameter	External exhaust required: 2 ports (4 inches in diameter)	External exhaust required: 2 ports (4 inches in diameter)

\*Requires a dedicated PC  
Specifications subject to change.

## Accessories

Being able to custom configure your laser system is a core philosophy that Universal Laser Systems has adopted to better meet the needs of our customers. We believe you should purchase only those options you actually need, not those that a manufacturer forces on you. It is also important that owners of Universal laser systems have the confidence in knowing that they can easily expand the capabilities of their laser system(s) as their business grows. You can easily add system accessories when you need them in the field (except air assist).

### **Coaxial Air Assist with Optics Protection (Non-Computer Controlled)**

High PSI (pressure) design with user-adjustable pressure regulator keeps optics clean and improves engraving and cutting of some materials. Coaxial design optimizes effectiveness. Choose between standard cone or optional back sweep for maximum flexibility.

### **Coaxial Air Assist with Optics Protection (Computer-Controlled)**

Computer-controlled high pressure design allows high or low PSI, plus the addition of another gas provides ultimate protection of optics and control of air/gas to improve cutting/engraving quality of special materials. Works on single lens or dual head; coaxial design optimizes effectiveness. Choose between standard cone or optional back sweep for maximum flexibility.

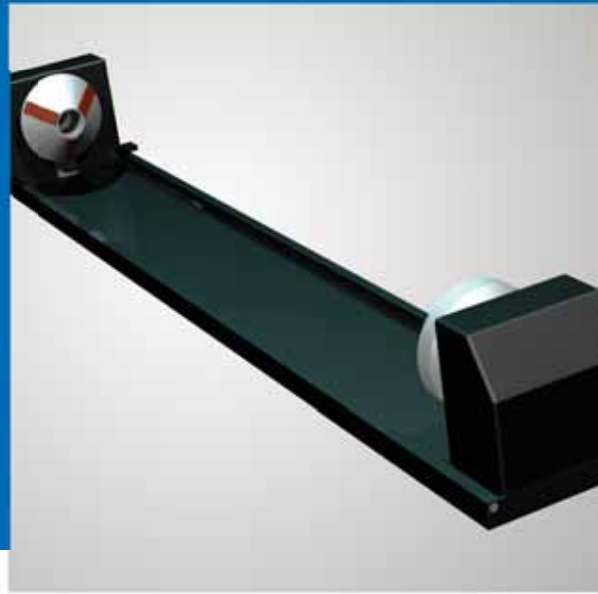

### **Rotary Fixture Attachment\***

The rotary attachment can be installed or removed without the need to restart the system and can accommodate most cylindrical items up to 8.5 inches in diameter. Allows very fast engraving, vector marking or cutting. Holds part on both ends, accommodates taper, can be run in high speed raster mode with lighter objects and also runs in vector mode. Rotates beyond 360 degrees in order to assure full wrap-around engraving. Wine bottles, coffee mugs and geometrically-shaped items can be rotated. A sensor detects the rotary attachment when installed and automatically makes all of the adjustments necessary for rotary marking and engraving.

### **Dual Head**

Beam splitter allows for simultaneous engraving or cutting of two items (same artwork) at the same time and can increase throughput of engraving or cutting (depending on available laser power and application).



### **Air Assist Back Sweep**

Recommended for use with the Computer-Controlled Compressed Air Unit, the Back Sweep attachment directs high pressure air toward the exhaust duct to suppress flaming and evacuate smoke, fumes and debris away from the material being processed. This is particularly useful for rubber or other materials that produce a lot of dust and debris during the engraving process.





#### **High Power Density Focusing Optics (HPDFO)<sup>™</sup>**

Exclusive, patented optics increases the power density of the laser to achieve dramatically improved resolution for applications requiring extremely fine detail. HPDFO makes it possible to engrave smaller text, produce higher resolution graphics and allows direct marking on some uncoated metals, including iron, stainless steel, chrome steel and titanium, without the need for metal marking compounds.

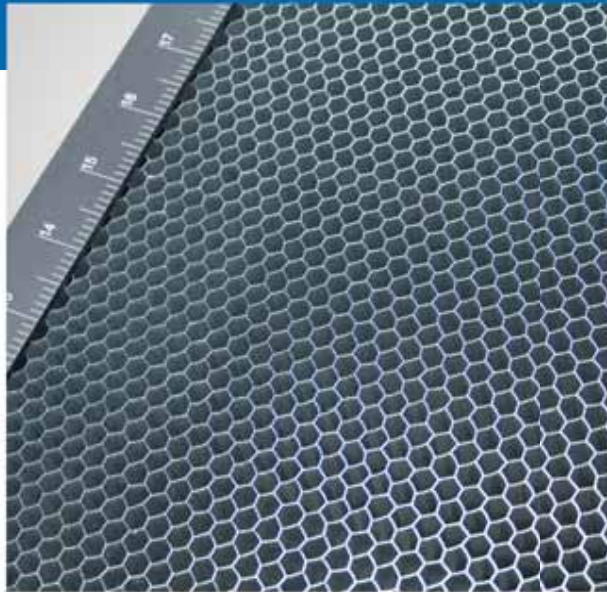

#### **Downdraft Honeycomb Cutting Table\***

Provides a cutting surface with minimal back reflection and light vacuum hold-down. Removes smoke from below cut, reducing potential of damage to bottom surface of material and improves cutting quality. Attached rulers assist in accurate part positioning. Greatly reduces need to clean work table.



#### **Air Assist Cone**

Recommended for use with the Computer-Controlled Compressed Air Unit, the Air Assist Cone directs high pressure air onto the material being processed to suppress flaming, thus improving cutting or engraving quality.



#### **Computer-Controlled Compressed Air Unit\***

Supplies dry, oil-free compressed air to enable air assisted cutting and engraving and extend the life of the laser system optics. The compressed air unit is activated only when jobs are in process. The compressor pump is noise-insulated to meet OSHA regulations.

#### **Air Dryer**

Removes moisture from air assist which can damage laser optics. Allows air assist to operate even in humid environments. Required with Compressed Air Unit.

\*The Professional Series automatically detects the installation of the rotary fixture attachment, downdraft honeycomb cutting table and compressed air unit and compensates to correct the focus when using the materials database or automatic focus.

# Applications

Universal's Professional Series of computer controlled CO<sub>2</sub> laser cutting and engraving systems are ideal for non-contact high speed cutting, deep engraving, precision scribing, intricate scoring and permanent marking. Laser cutting, marking and engraving capabilities are currently in great demand in the automotive, aviation, electrical and electronics, food, packaging and printing industries. Here are just a few of the things you can do with a Universal laser system:

Engraving of Fabric Floor Mats

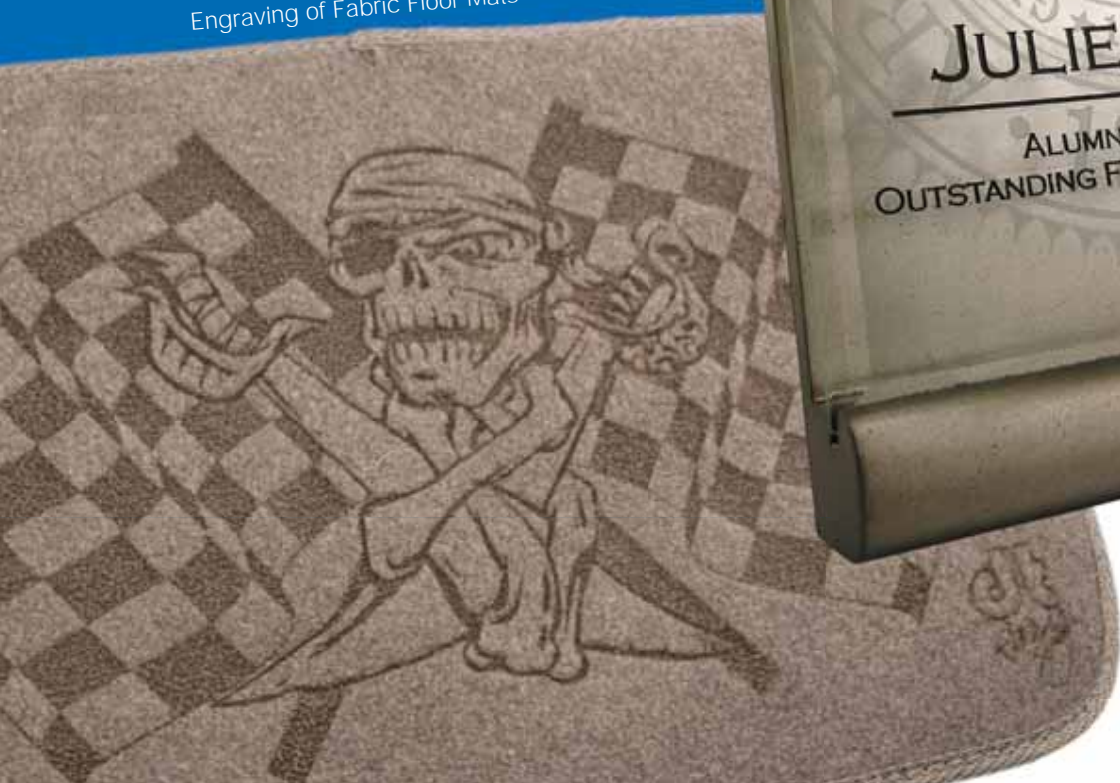

Etching and Color Filling of Glass Awards



- Mark UID 2-D Data Matrix Codes
- Permanently Mark Industrial Parts
- Produce Packaging Prototypes and POP Displays
- Produce Advertising Specialty Items
- Create Personalized Gifts
- Engrave Awards
- Personalize Jewelry
- Produce Embroidery and Appliqué
- Engrave Patterns onto Fabrics
- Fabricate 3D Signage
- Produce Braille Signage
- Cut and Engrave Lighted Displays





Marking of Chrome-plated Sockets

- Generate Name Badges/ID Tags
- Produce Desk Accessories
- Produce Rubber Stamps and Seals
- Produce Architectural Models
- Cut and Engrave Textiles
- Engrave Cabinetry
- Etch Flexible Circuits
- Burn and Brand Wood
- Produce Complex Inlays
- Create Scrapbooking Items
- Cut Out Stencils, Templates and Masks
- Cut Film and Overlays
- Etch Key Pads
- Engrave Control Panels
- Etch Membrane Switches
- Fabricate Gaskets
- Degate Plastic Parts
- Mark Medical Instruments
- Produce Flexographic Plates
- Mark Parts for Traceability

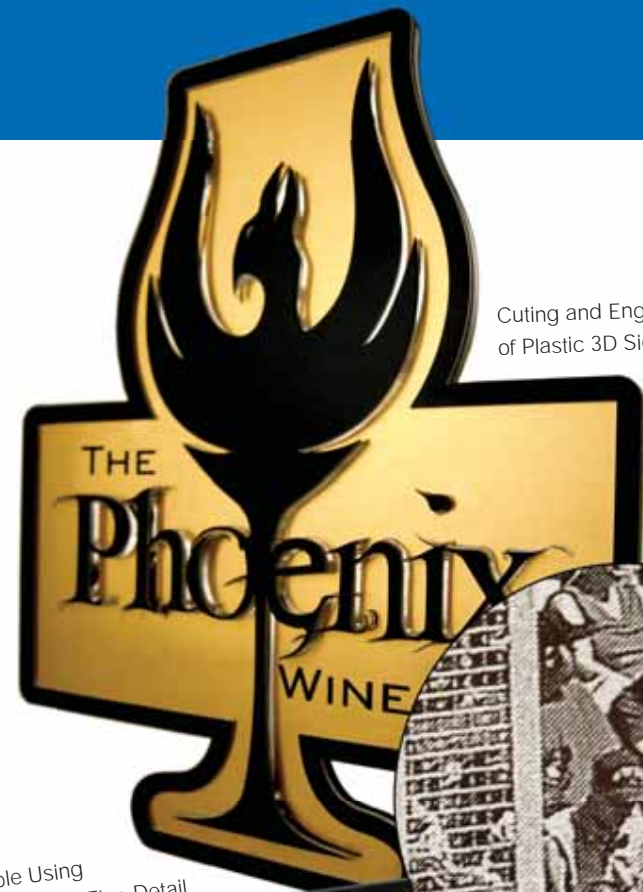

Cutting and Engraving of Plastic 3D Signage

Photo Engraving of Marble Using HPDFO Accessory for Extremely Fine Detail



Photo Engraving of Plastic Frame



# Service and Support

Universal builds the most reliable CO<sub>2</sub> lasers and laser systems in the industry. In fact, 99% of the laser systems that Universal has manufactured are still operational, including some of the very first laser systems we placed in the field. We recognized from the start that reliability is essential to your profitability. Our superior engineering and innovative technology result in systems that provide years of profitable, reliable and productive service.

Keeping your laser system up and running at the least possible expense and inconvenience to you is a primary concern for us at Universal. We believe that making you wait for a service technician visit is a waste of your valuable time and money. That's why we engineered the parts in our Professional Series laser systems to be modular in design and easy to replace in the field. Most common repairs can be made quickly and cost-effectively by the user – in many cases simply by changing out a single component. Most parts are designed so that they cannot be incorrectly fitted, and many operations can be performed with common hand tools. Parts for current models are in stock and available for express shipment.

When you purchase a Universal laser system, you deserve world-quality support. When you have a question, we'll be there to provide the answers. Service and support are always available by telephone, fax and email. Comprehensive and easy-to-understand manuals are supplied with all Professional Series systems and on-site service is available.

# Warranty

## Up to Five (5) Year Warranty (Platforms & CO<sub>2</sub> Lasers)

Each Professional Series laser system includes comprehensive warranty coverage (one year on system, two years on laser cartridge), including optics and belts. Warranty extensions can be added to any laser or platform for long term predictable cost and additional peace of mind.

## RoHS Compliant

In order to help foster and maintain a cleaner environment, Universal's Professional Laser Series are manufactured in compliance with the Restriction of Hazardous Substances (RoHS) Directive. RoHS restricts the use of certain hazardous materials in the manufacture of various types of electronic and electrical equipment.

## Patented Technology

Universal's Professional Series laser systems are protected under one or more of U.S. Patents 5,051,558; 5,661,746; 5,754,575; 5,867,517; 5,881,087; 5,894,493; 5,901,167; 5,982,803; 6,181,719; 6,313,433; 6,342,687; 6,423,925; 6,424,670; 6,983,001; 7,060,934. Other U.S. and international patents pending.



# Superior Representative Network

- Universal Laser Systems' sales representatives are experts in computer-controlled CO<sub>2</sub> laser cutting, engraving and marking.
- Customer sales, service, applications and training support are available.
- Service agreements are available for long term predictable cost and peace of mind.
- Support is available by phone, fax and email. Factory on-site and local assistance are also available.



## Universal Laser Systems, Inc. - Headquarters

North America • South America • Asia • Oceania • India

7845 E. Paradise Lane  
 Scottsdale, Arizona 85260 USA  
 Toll Free: 800-859-7033  
 Fax: 480-483-5620  
 Email: sales@ulsinc.com

## Universal Laser Systems GmbH

Europe • Middle East • Africa

Lerchenfelder Guertel 43  
 A-1160 Vienna, Austria  
 Phone: +43 1 402 22 50  
 Fax: +43 1 402 22 50 10  
 Email: eurosales@ulsinc.com

## Universal Laser Systems Co., Ltd.

Japan

The Yokohama Landmark Tower, 15th Fl.  
 2-2-1-1 Minato Mirai, Nishi-ku  
 Yokohama-shi, Kanagawa-ken, 220-8115  
 Japan  
 Phone: +81 45-224-2270  
 Fax: +81 45-224-2279  
 Email: japansales@ulsinc.com

For a local rep, contact the nearest ULS office.

Material	Engrave	Cut	Material	Engrave	Cut
ABS Plastic	•	•	Silicone	•	•
Acrylic	•	•	Silk	•	•
Avonite	•	•	Stone	•	
Brick	•		Styrene	•	•
Cardboard	•	•	Tile	•	
Ceramic	•		Travertine	•	
Chipboard	•	•	Twill	•	•
Corian®	•	•	Wood	•	•
Cork	•	•			
Delrin®	•	•			
Fabric	•	•			
Fiberglass	•				
Foam	•	•			
Fountainhead	•	•			
Glass	•				
Granite	•				
Kevlar	•	•			
Laminated Plastics	•	•			
Leather	•	•			
Marble	•				
Masonite®	•	•			
Mat Board	•	•			
Melamine	•	•			
Mother of Pearl	•	•			
MDF	•	•			
Mylar®	•	•			
Nylon	•	•			
Paper	•	•			
Particle Board	•	•			
Polycarbonate	•	•			
Polypropylene	•	•			
Polyester	•	•			
Pressboard	•	•			
Resin	•	•			
Rubber	•	•			

Guideline: 10 watts can cut approximately 1/8";  
 25 watts can cut approximately 1/4"; 50 watts  
 can cut approximately 1/2"; 100 watts can cut  
 approximately 3/4".

## Metal Marking

Material	Mark without Metal Marking Compounds	Mark with Metal Marking Compounds
AlumaMark®	•	
Aluminum		•
Anodized Aluminum	•	
Brass		•
Carbide*	•	•
Cobalt*		•
Copper		•
Iron*	•	•
Nickel		•
Painted Brass	•	
Pewter*	•	•
Stainless Steel*	•	•
Steel*	•	•
Titanium*	•	•
Tungsten	•	•

\* Can be marked directly (without the need for Metal Marking Compounds) using High Power Density Focusing Optics™ (HPDFO).

**WARNING! Laser system must be constantly monitored during use. Exposure to the laser beam may cause ignition of combustible materials which can cause severe damage. Review operations manual for proper procedures prior to use.**

Engineering Excellence. Innovative Technology.

**UNIVERSAL**  
LASER SYSTEMS INC.

[www.ulsinc.com](http://www.ulsinc.com)